

# YIFAN

## JC Series Jaw Crusher



Leading crushing and screening equipment manufacturer in China

Zhengzhou YiFan Machinery Co.,Ltd(the share-holder is Shande Technology (Beijing) Co., Ltd) has its headquarter in Beijing. It is a famous manufacturer of crushing and screening equipment and provides series stone crusher and crushing equipment for customers.



# YIFAN

ZHENGZHOU YIFAN MACHINERY CO.,LTD

Tel:+86 371 64628852 Web : [www.yfcrusher.com](http://www.yfcrusher.com) Add : Zhengyuan Rd, Xinyang, Zhengzhou Henan 450100, China

JC series Jaw Crusher owns world's most advanced crushing technology. It applies finite element analysis and successfully developed on the basis of 10,000 YIFAN jaw crusher design and building experience.

Compared with traditional jaw crusher, JC series Jaw Crusher pay more attention to the details. Adopts high-strength material, first-class manufacturing process, the series leads to the advantage of excellent-strength structure, reliable equipments, higher crushing ratio, bigger capacity and lower cost.



## Features and Benefits

### 1. Sturdy Structure

Two kinds of Frames: Welded and Packaged. Usually, Small and medium sized model adopts welded, large model adopts packaged.

Welded frame adopts wide transitional round edge, significantly reducing the stress concentration, ensure the frame under equal strength. It owns the features of good impact resistance and low failure rate, bears same pressure, etc.

Packaged frame uses advanced modularization, no-welding frame structure design, high endurance strength and reliability. The whole set assembling design is convenient for the transporting and installation, especially suitable for installation of underground mine shaft, high altitude mine, as well as other narrow and difficult transporting place.

### 2. Extraordinary Cavity Design

Symmetrical V-shaped cavity design, high inclination-angle of the toggle, big stroke and reasonable speed, allows a bigger feeding size, higher capacity, uniform particle size and lower wearing of the plate.

### 3. Long Working Life of the Heavy-duty Movable Jaw Assembly.

Heavy-duty Movable Jaw Assembly adopts heavy-duty eccentric shaft, high quality heavy-load rolling bearings and finite element software optimized movable jaw plate ensuring impact resistance and high stability of moving jaw assembly; labyrinth seal and centralized lubrication system guarantee the bearing lubrication oil is not contaminated and lubrication becomes more convenient. Therefore the assembly can have a long working time and stability.

### 4. Shield Design for the Movable Jaw

Heavy shield is installed above the movable jaw to avoid the material impact. It can effectively protect the movable jaw and its internal bearing from damaging.

### 5. Overall Bearing Support

Overall cast steel bearing support fully compatible with the rack, avoiding the combined bearing support has a unnecessary radical load on the bearing during the fastening process, making the bearing to run more smoothly.

### 6. Convenient Particle Size Adjustment

JC series Jaw Crusher adopts mechanical or hydraulic adjustment for the discharge range, compared with shim adjustment, double wedge adjustment operations is simpler, secure, fast, and saves more downtime.

### 7. Integrated Motor Installation

Integrated installation of motor seat and frame can not only save installation space, reduce the length of v-belt, but also can prolong v-belt working time, since the frame, motor seat, synchronous move of motor, adjustable motor seat bring v-belt tension adjustment.

### 8. Vibration Absorption Design

Crusher fixed by rubber vibration absorption device, which can effectively absorb vibration peak, while allow the vertical and longitudinal displacement of the crusher, thus reducing the impact on the foundation.

## Structural Drawing

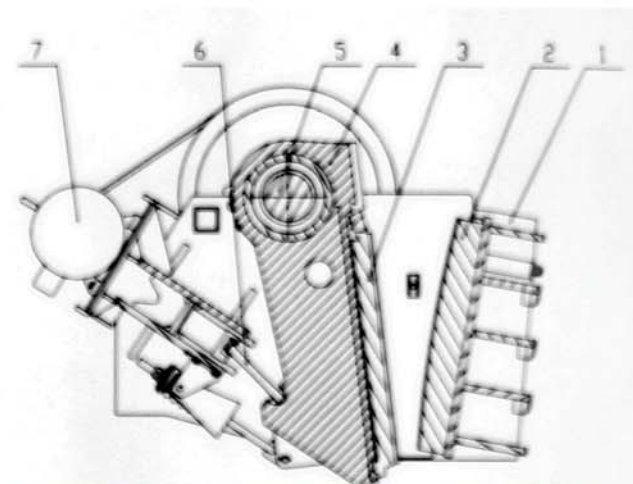

1. Frame
2. Fixed Jaw Plate
3. Movable Jaw Plate
4. Movable Jaw
5. Eccentric Shaft
6. Toggle
7. Motor



# Technical Date

Model	Max Feed Size(mm)	Overall Dimensions(mm)	Capacity(t/h)	Motor Power(kw)
JC231	425	40-150	50-250	55-75
JC340	500	60-175	85-300	75-90
JC442	585	70-200	120-520	90-110
JC445	680	70-200	150-575	110-132
JC549	800	100-250	260-810	132-160
JC555	900	125-250	360-920	160-200
JC663	1000	150-300	500-1250	220-250
JC779	1250	175-300	700-1500	400



SHANDE TECHNOLOGY (BEIJING) CO.,LTD.  
Headoffice Add: Rm422,Nanpeilou Jianshebu,No.11  
Sanlihe Rd,Beijing, China  
Tel: 010-57811256  
Fax: 010-57811257

ZHENGZHOU YIFAN MACHINERY CO., LTD.  
Factory Add: Zhengyuan Rd, Xingyang, Zhengzhou Henan  
Zip Code: 450100  
Tel: +86 371 64628852  
Fax: +86 371 64628872  
Web: [www.yfcrusher.com](http://www.yfcrusher.com)  
E-mail:[yifan@yfmac.com](mailto:yifan@yfmac.com)

# YIFAN